

QUAD OR TRIPLE MOUNT MAILBOX POST ASSEMBLY INSTRUCTIONS

IMPORTANT! Before installing your Whitehall mailbox posts, consult your local branch of the US Post Office for road set back and height requirements from roadbed or curb. See Figure 1.

- A - 4" x 4" x 54" Cross Bar with Welded Mounts - 1
- B - 4" x 4" x 84" Vertical Posts - 2
- C - Finials - 2
- D - Whitehall Mailboxes - 4 (Sold Separately)
- E - Newspaper Tubes - 4 (Sold Separately)
- F - L Brackets - 4
- G - 10-24 x 1/2" Black Panhead Screws - 16
- H - 1/4"-20 x 3/16" Black Set Screws - 2
- I - Allen Wrench for Set Screws - 1
- J - 3/8"-16 x 5.5" Black Panhead Bolts - 4
- K - 3/8"-16 Black Panhead Nuts - 4
- L - Washers - 4

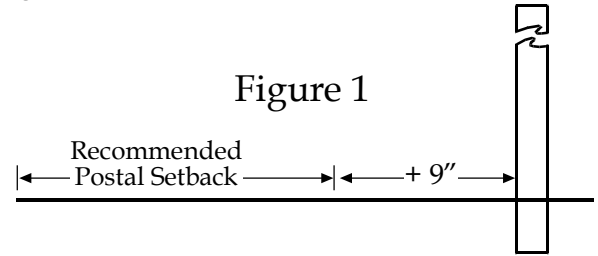

Figure 1

Post Assembly:

- 1) Attach L Brackets (F) to Vertical Posts (B) using 10-24 x 1/2" Screws (G) provided. (See Figure 2)
- 2) Slide Cross Bar (A) over L Brackets (F) and attach using 10-24 x 1/2" Screws (G) provided making sure to position mailbox mountings up. (See Figure 3)
- 3) Repeat Steps 1 - 2 for opposite end of Mailbox Mount.
- 4) Attach Finial (C) on top of Vertical Post (B) using Allen Wrench (I) and 1/4"-20 x 3/16" Set Screw (H) (See Figure 3)

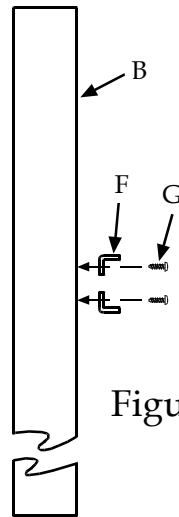

Figure 2

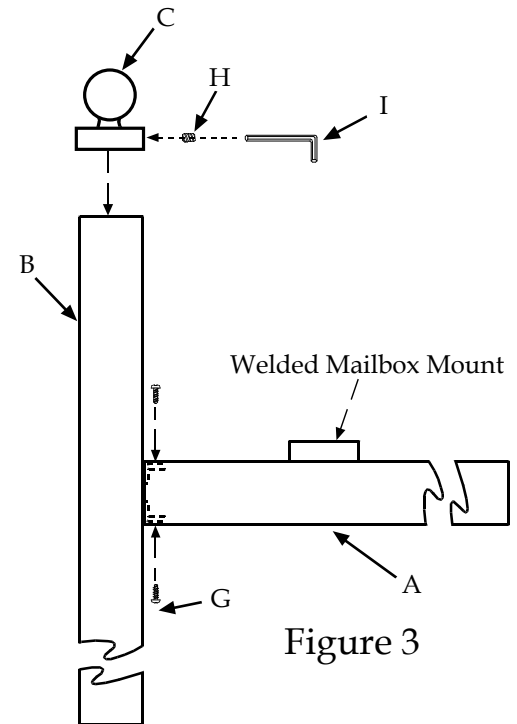

Figure 3

Installing the posts in the ground:

- 1) Consult your local post office for recommended road setback and height requirements. Add 9" and mark position on ground for front edge of post. (See Figure 1)
- 2) Consult MISDIG for possible interference with underground utilities.
- 3) Dig holes 58" on center (45.332" for Triple Mounts). Determine depth of holes using the Post Office height requirement (X), subtracting the height from the top of the cross bar to the bottom of the post. I.E...70" - X = Hole Depth. (See Figure 4)
- 4) Place post assembly in holes and partially backfill. Position for level on cross bar and plumb on vertical post. NOTE: Double check set back measurement.
- 5) Complete back fill of the post holes packing the earth firmly. Note: For permanent installation, use concrete mix to backfill unless it is against local post office or county road commission guidelines.

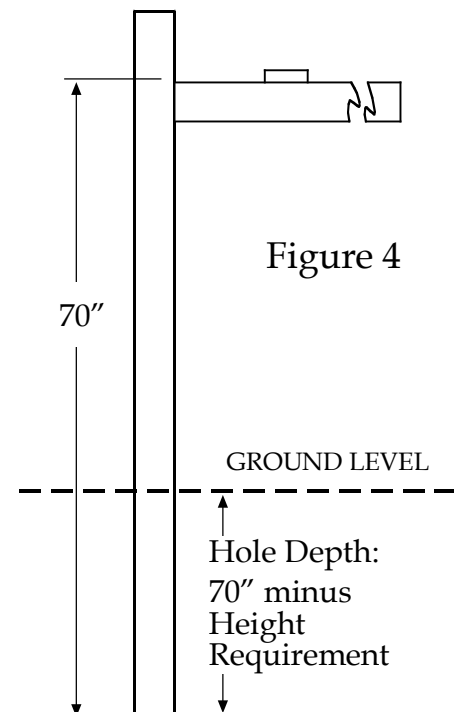
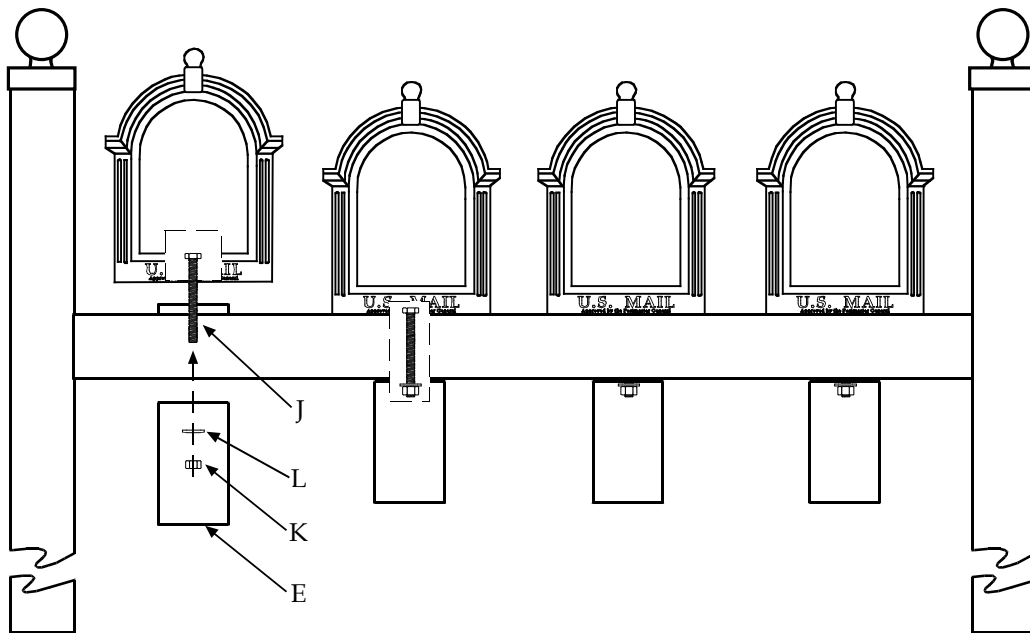
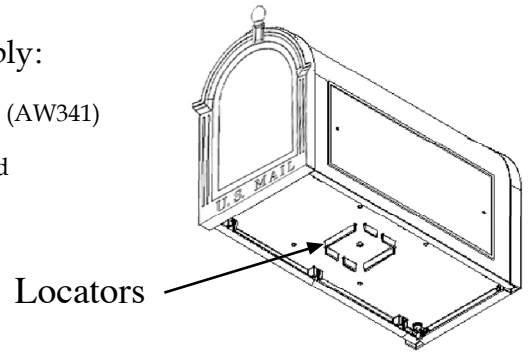

Figure 4

QUAD OR TRIPLE MOUNT MAILBOX POST ASSEMBLY INSTRUCTIONS

Attaching your Whitehall Mailboxes to the Quad Mount Post Assembly:

- 1) Attach your personalized door plaque to the mailbox using the instruction sheet provided. (AW341)
- 2) Set the mailbox on the crossbar aligning the locators on the bottom of the box to the welded locators on the crossbar.
- 3) Place the 3/8"-16 x 5.5" bolt (J) inside the mailbox, through the hole in the base of the box, through the crossbar and into the newspaper tube (E). Reach inside the tube with a small socket wrench and attach the washer (L) and nut (K) to the end of the bolt (J).
- 4) Make sure all units are square to the post assembly and tighten bolts.



FINISHED ASSEMBLY

